

Clutch Disc

Inspection

1. Remove the clutch disc.
2. Inspect lining of the clutch disc for signs of slipping or oil. Replace it if it is burned black or oil soaked.

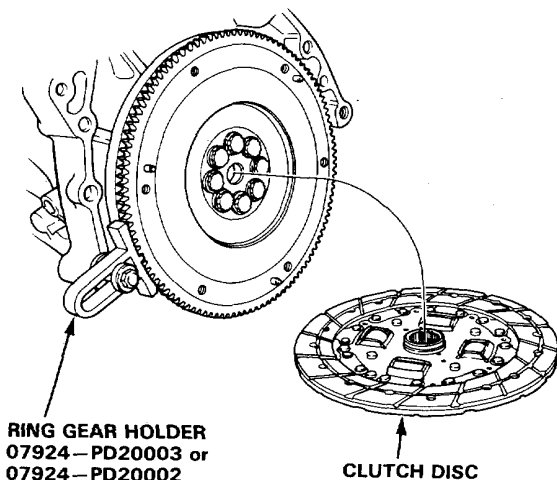

3. Measure the clutch disc thickness.

Clutch Disc Thickness:

Standard (New): 8.5–9.2 mm (0.33–0.36 in.)

Service Limit: 6.1 mm (0.24 in.)

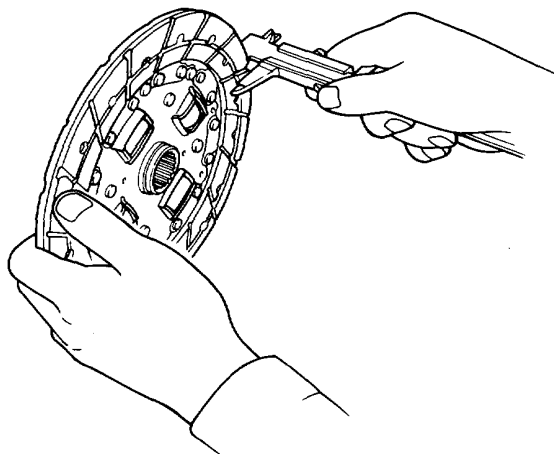

4. Check for loose rubber torsion dampers. Replace the clutch disc if any are loose.
5. Measure the depth from the lining surface to the rivets, on both sides.

Rivet Depth:

Standard (New): 1.3 mm (0.051 in.) min.

Service Limit: 0.2 mm (0.008 in.)

